



Dimensions and weights			
Width			
Including packaging	[mm]	580	
Excluding packaging	[mm]	515	
Depth			
Including packaging	[mm]	740	
Excluding packaging	[mm]	599	
Height			
Including packaging	[mm]	935	
Excluding packaging	[mm]	732	
Weight			
Including packaging	[kg]	66	
Excluding packaging	[kg]	54	
Safety clearances			
Rear	[mm]	50	
Right	[mm]	50	
Left (larger gap recommended for servicing)	[mm]	50	
Top (for ventilation)	[mm]	500	

Height with easyTOUCH panel			
Appliances with an easyTOUCH panel are 20 mm higher than the specified value.			

Electrical connected load ratings			
3N~ 400V 50/60Hz (3/N/PE)			
Rated power consumption	[kW]	5,7	
Convection power	[kW]	5,4	
Motor power	[kW]	0,25	
Rated current	[A]	11,8	
Fuse	[A]	16	
Recommended conductor cross-section for wires laid uncovered in air up to 5 m in length.	[mm ²]	5G2.5	
1N~ 230V 50/60Hz (1/N/PE)			
Rated power consumption	[kW]	3,0	
Convection power	[kW]	2,7	
Motor power	[kW]	0,25	
Rated current	[A]	13,1	
Fuse	[A]	16	
Recommended conductor cross-section for wires laid uncovered in air up to 5 m in length.	[mm ²]	3G2.5	

Heat output			
Heat output			
Latent heat	[kJ/h]	1000	(0.28 kW)
Sensible heat	[kJ/h]	1100	(0.31 kW)

Water connection			
Water drawer holding capacity			
Drinking water drawer	[l]	5,5	
Wastewater drawer	[l]	4,5	

Water quality			
water quality for general use		Drinking water quality	
Hardness for injection, condenser, cleaning			
German degrees of hardness (general hardness: GH)	[°dH]	4 - 7	
French degrees of hardness	[TH]	7 - 13	
English degrees of hardness	[°e]	5 - 9	
International	[ppm]	70 - 125	
Chemical	[mmol/l]	0,7 - 1,3	
Properties			
temperature (T)	[°C]	max. 40	
conductivity	[µS/cm]	min. 20	
pH		6,5 - 8,5	
Cl ⁻	[mg/l]	max. 100	
SO ₄ ²⁻	[mg/l]	max. 150	
Fe	[mg/l]	max. 0.1	
Carbonate hardness (KH)	[°dH]	Low GH	

Maximum permissible loading weight			
GN (containers, shelf-grills, baking trays)			
Per combi steamer	[kg]	13	
Per shelf	[kg]	5	

Capacity			
Quantity			
GN 2/3 depth 40 mm	[Qty]	6	
GN 2/3 depth 65 mm	[Qty]	4	
Plate up to Ø 28 cm	[Qty]	4	

Appliance technical standards			
Degree of protection		IPX4	
Approval mark according to national regulations		TÜV/GS, DIN GOST TÜV, SVGW	
Noise emission			
Measured	[dBA]	max. 60	

Appliance with standard controls

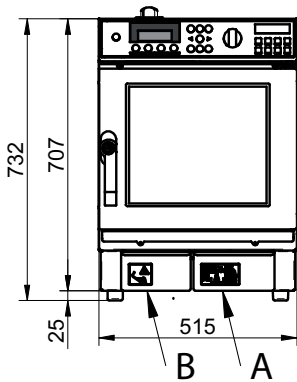

Appliance with easyTOUCH controls

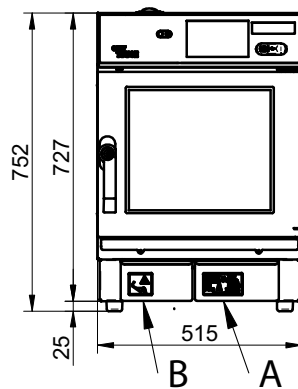

Side view

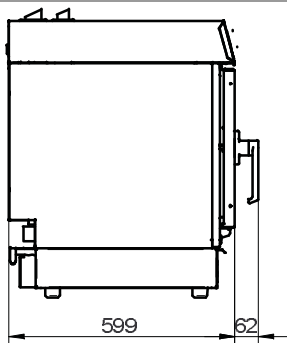

View from above with wall clearances

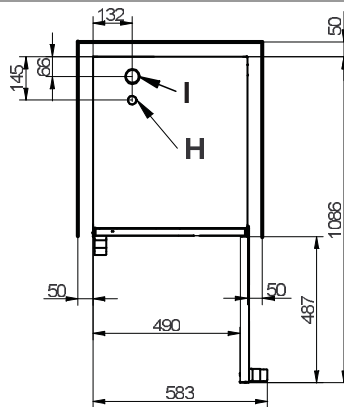

Connections on the underside

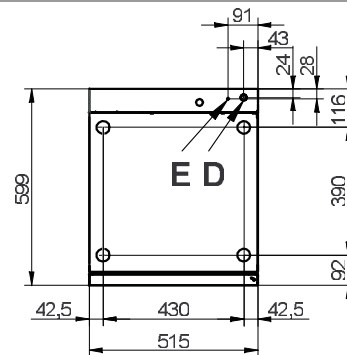

Meaning of labeled elements

- A Drinking water drawer
- B Wastewater drawer
- D Electrical supply
- E Equipotential bonding
- H Air vent
- I Ventilation port

This document is to be used solely for planning purposes. Please refer to the Installation manual for instructions on installation and positioning.

